



**INDUSTRIAL VALVES & FITTINGS CO.**

**WE ARE THE BEST LEADING  
MANUFACTURER OF  
INDUSTRIAL VALVES**

# Dual Plate Check Valves



**ALKA TECH is an ISO 9001:2015 approved reputed Manufacturer of Industrial Valves founded by Mr. John Mascarenhas with Joint Venture collaboration FUTURE VALVE TECHNOLOGIES a team having experience exclusively in the Design and Production of Valve technology for more than two decades.**

**We are driven by the ability to provide innovative & Sustainable solutions to your business needs.**

- High Quality
- Cost Effective
- Finished product
- Delivery On time
- Advanced Technology
- Expert Engineers

**We are focused on accomplishing complete consumer loyalty through Design, Development, Manufacturing, and supply of reliable quality Industrial Valves with the point of zero rate dismissal while remaining financially savvy and serious. This will be accomplished by collaboration and ceaseless improvement in all the regions of activity.**

# COMPANY PROFILE

Alka Tech Industrial Valves & Fittings Co. established to supply high performance valves to critical applications. Our team over decades of experience in valve design, manufacturing, quality control and deliveries understands the customer challenges in sourcing quality valves in the scheduled time.

In order to meet such demand company operates on sophisticated ERP system which includes project planning and management. Company has latest software for design and automated test benches of latest technology.

Our supplier control process ensured experienced suppliers and sub-vendors meet quality requirements of raw materials and accuracy of machined parts.

Company manufacture and supply below types of valves in soft and metal seated;

- Process to Instrument and Piping Valves Double Block and Bleed (DBB)
- Ball valves Floating and Trunnion
- Butterfly valves Double and Triple offset
- Piston Valves
- GGC Valves

Company management and employees have expertise in international standards and customer specifications with the past experience on working with a multinational valves manufacturing company engaged in supply of valves to various reputed EPCs and users like: Shell Global, Saudi Aramco, PDO, ADNOC, KOC, QP, Petrobras, Petronas, EIL, MECON, ONGC, HPCL, IOCL, BPCL.

We are focussed on manufacturing of valves for sectors like:

Oil, Gas, Power, Water, Chemical, Fertilisers, Nuclear, Mining LNG, Marine and Hydrogen sectors.

## WHY US

### IN HOUSE RESEARCH & DEVELOPMENT

Our Engineering, Research and Development facilities uses latest technology and software.

Design validation tests done in house as per MESC/SPE/77/300 series and API 6D. Fugitive emission test done a per ISO 15848, API 624 and API 641.

### ERP FOR MANUFACTURING PROCESSES

ERP is implemented across all functions for effective process control. Specific project management module is implemented to ensure best quality valves are delivered on time.

### IN HOUSE TESTING FACILITY

Production testing facility uses modern automated equipment and software.

### QUALITY, HEALTH & ENVIRONMENT MANAGEMENT SYSTEM

We at Alka Tech valve strives to create a culture where we take personal responsibility for the health, safety and environment. We have QHSE maintained through our advanced ERP.

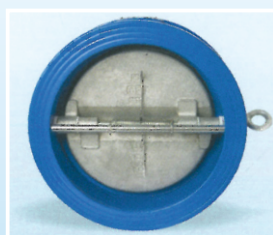

**Wafer End - Retainer Type / Retainer Less**  
Size Range : 2" ~ 48"



**Lugged End - Retainer Type / Retainer Less**  
Size Range : 2" ~ 10"

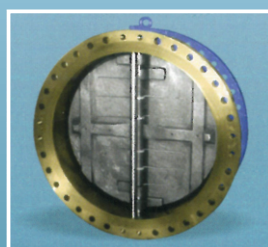

**Flanged End - Retainer Type / Retainer Less**  
Size Range : 12" ~ 48"



**Hub End - Retainer Type / Retainer Less**  
Size Range : 2" ~ 20"

02	Profile
04	Design Features, Application, Installation
05	Technical Information
06	Dual Plate Check Valve ANSI B16.5 - #125, ANSI B16.5 - #150 Wafer Type Rubber Lined
07	Dual Plate Check Valve ANSI B16.5 - #125 Wafer Type
08	Dual Plate Check Valve ANSI B16.5 / B16.47 Series A - # 150 Wafer, Lug & Flange Type
09	Dual Plate Check Valve ANSI B16.5 - #300 Wafer, Lug & Flange Type
10	Dual Plate Check Valve ANSI B16.5 - #600 Wafer, Lug & Flange Type
11	Dual Plate Check Valve ANSI B16.5 - #900 Wafer, Lug & Flange Type
12	Dual Plate Check Valve ANSI B16.5 - #1500 Wafer, Lug & Flange Type
13	Dual Plate Check Valve ANSI B16.5 - #2500 Wafer, Lug & Flange Type
14	Material Selection Guide
16	Ordering Instruction
18	Hub End Check Valve

## DESIGN FEATURES

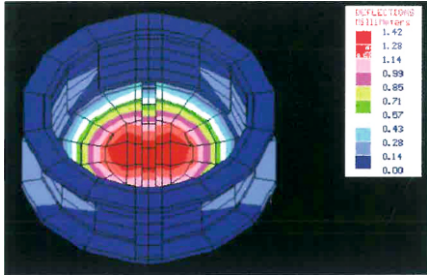

- Design by Wire
- FEM Stress Analysis

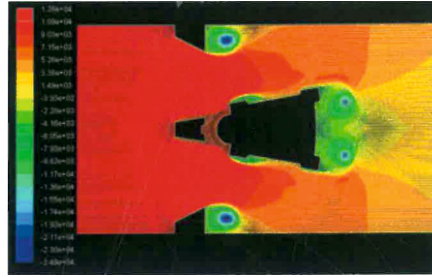

- CFD - Computational Fluid Dynamic Software helps to achieve Low Pressure Drop ( $\Delta P$ ), High Cv Design



- Retainerless Design is intrinsically **FIRE SAFE**
- Stellited Lapped Seat
- High Performance Spring Design
- Shock Bumper Prevents Slamming with Spring and Pins
- Serrated Finish 125 - 250 AARH or RTJ As per requirement
- No Fugitive Emission

## APPLICATION

- In down stream of pump, prevents flow reverser
- In wellhead injection lines, for Oil Ring and Platforms
- In Gas and Oil Processing plants and refinery on Delivery / Discharge side of pumps
- For LNG and Chemical storage tank, use discharge side of pump to prevent backflow

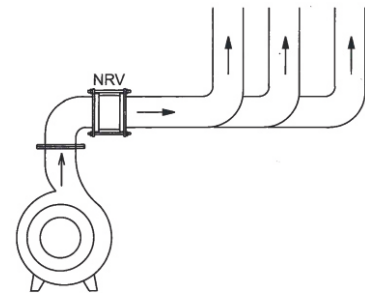

## INSTALLATION

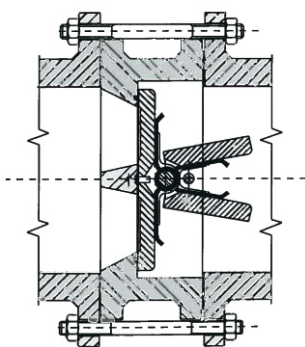

Wafer Design

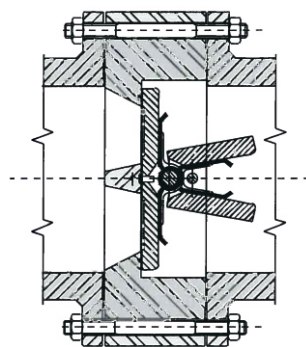

Solid Lug Design

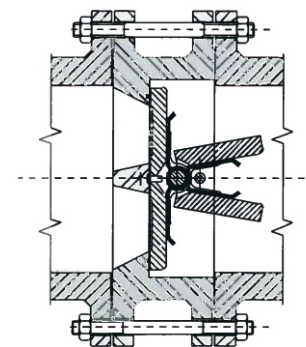

Flanged Design

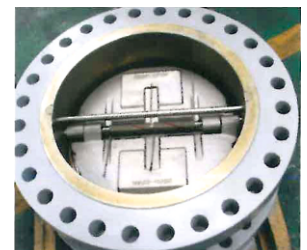

# TECHNICAL INFORMATION

## Pressure Drop Information

- The below showcased curves show the pressure drops available with Standard Torque Springs and the Dual Plate Check Valve in horizontal flow
- Dual Plate Check Valves should be installed in horizontal flow with pins vertical for best performance. For other installations, Contact the Factory
- We can Size Dual Plate Check Valves relative to your system Parameter

## Valve Life V/S. Cost V/S. Energy Saved

All these aspects are quite inter-related. The mathematical expression for energy saved  
 Power Saved = Difference of Power Consumed (kw) x Cost per kw

The Difference  
 Of Power Consumed (kw) = 
$$\frac{\text{H.P.} \times \text{Head Difference} \times \text{Wt. of Liquid per min.} \times 0.76}{33,000}$$

The above Head difference in feet of water column  
 Wt. in lbs  
 H.P. is British Horse Power

## Cv Valve

Cv is defined as the quantity of fluid measured in U.S. Gallons per Min. when the Pressure drop across the valve is maintained at 1 psi  
 The relation between Flow & Pressure drop is expressed as

$$Q = C_v \sqrt{\frac{\Delta P}{G}}$$

Q = Flow in U.S. Gallons per min.      P = Differential Pressure in psi.  
 Cv = Valve Co-efficient                      G = Specific gravity of Fluid

## Pressure Drop Curve

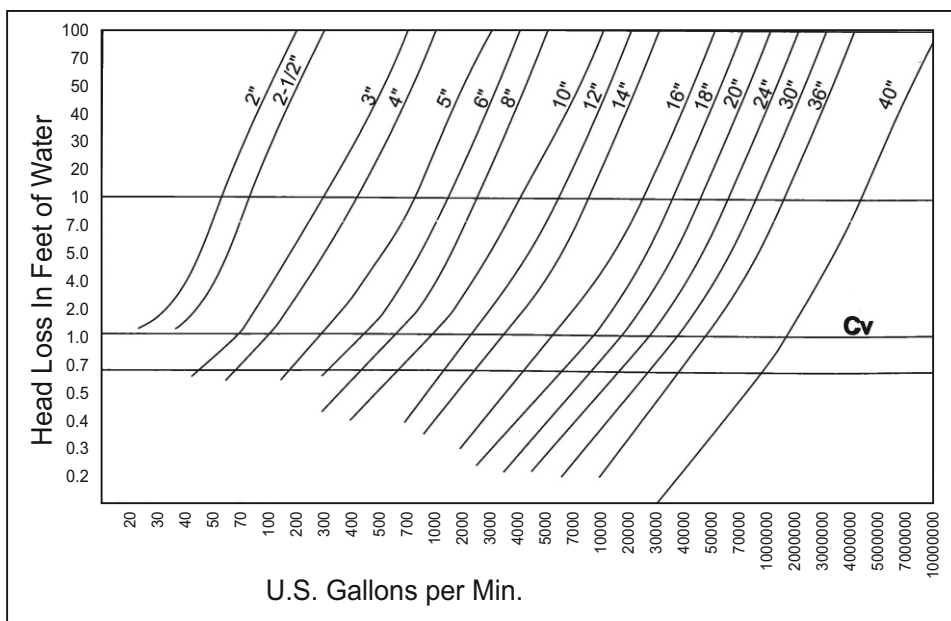

## Cv Value

Value	Size	Class
Inch	mm	150-300
2	50	75
2 1/2"	65	95
3"	80	191
4"	100	377
5"	125	483
6"	150	821
8"	200	1,590
10"	250	2,920
12"	300	4,470
14"	350	5,870
16"	400	8,690
18"	450	10,940
20"	500	14,290
24"	600	23,000
30"	750	37,200
36"	900	59,000
42"	1050	92,000
48"	1200	126,000

# DUAL PLATE CHECK VALVE

## ANSI # 125

**Features** : Rubber Lined  
**Size** : 2" ~ 24"  
**Rating** : ANSI # 125

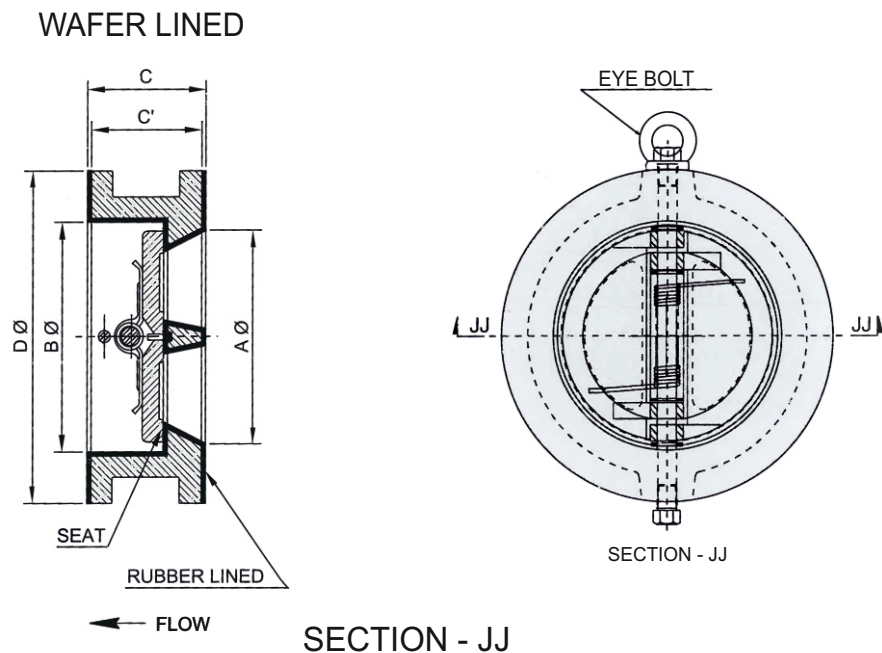

### Installation Dimensions

Size : 2" ~ 24"

Rating : ANSI # 125

Flange : ANSI B 16.5

SIZE Inches (DN)	AØ mm	BØ mm	C mm	C' mm	DØ mm	End Facing	Approx weight in kg. Wafer
2" (50)	50	60	60	54	105	SF	3
2.5" (65)	65	75	66	60	124	SF	5
3" (80)	76	90	73	67	134	SF	7
4" (100)	100	114	73	67	172	SF	9
5" (125)	125	135	89	83	196	SF	14
6" (150)	150	168	101	95	222	SF	16
8" (200)	200	215	133	127	279	SF	26
10" (250)	250	265	146	140	340	SF	48
12" (300)	300	315	187	181	409	SF	78
14" (350)	350	365	190	184	450	SF	90
16" (400)	400	418	197	191	514	SF	100
18" (450)	450	470	209	203	549	SF	140
20" (500)	500	520	219	213	603	SF	180
24" (600)	600	620	228	222	718	SF	210

# DUAL PLATE CHECK VALVE

## ANSI # 125

**Features** : Retainer Type / Retainer Less  
**Size** : 2" ~ 24"  
**Rating** : ANSI # 125

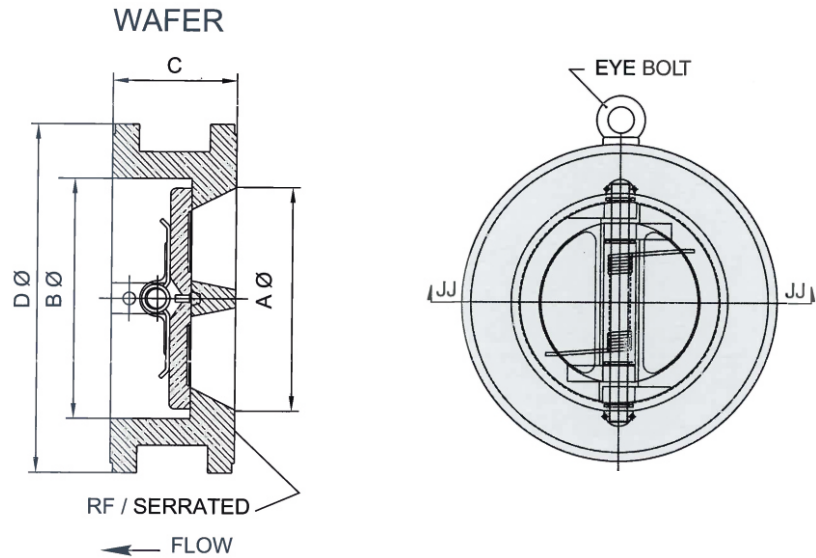

SECTION - JJ

### Installation Dimensions

Size : 2" ~ 24"

Rating : ANSI # 125

Flange : ANSI B 16.5

SIZE Inches (DN)	AØ mm	BØ mm	C mm	DØ Wafer mm	End Facing	Approx weight in kg. Wafer
2" (50)	50	60	54	105	RF/Serrated	3
2.5" (65)	65	75		124		5
3" (80)	76	90	57	134	RF/Serrated	7
4" (100)	100	114		172		9
5" (125)	125	135	70	196	RF/Serrated	14
6" (150)	150	168		222		16
8" (200)	200	215	95	279	RF/Serrated	26
10" (250)	250	265		340		48
12" (300)	300	315	143	409	RF/Serrated	78

Size : 14" ~ 24"

Rating : ANSI # 125

Face To Face : API 594

SIZE Inches (DN)	AØ mm	BØ mm	C mm	DØ Wafer mm	End Facing	Approx weight in kg. Wafer
14" (350)	350	365	184	450	RF/Serrated	90
16" (400)	400	418	191	514	RF/Serrated	100
18" (450)	450	470	203	549	RF/Serrated	140
20" (500)	500	520	213	603	RF/Serrated	180
24" (600)	600	620	222	718	RF/Serrated	210

1. Size : 2" to 12", Face To Face Dimension 'C' As Per Manufactures Standard 2. Installation between ANSI B16.5 Flanges

# DUAL PLATE CHECK VALVE

## ANSI # 150

**Features** : Retainer Type / Retainer Less  
**Size** : 2" ~ 48"  
**Rating** : ANSI # 150

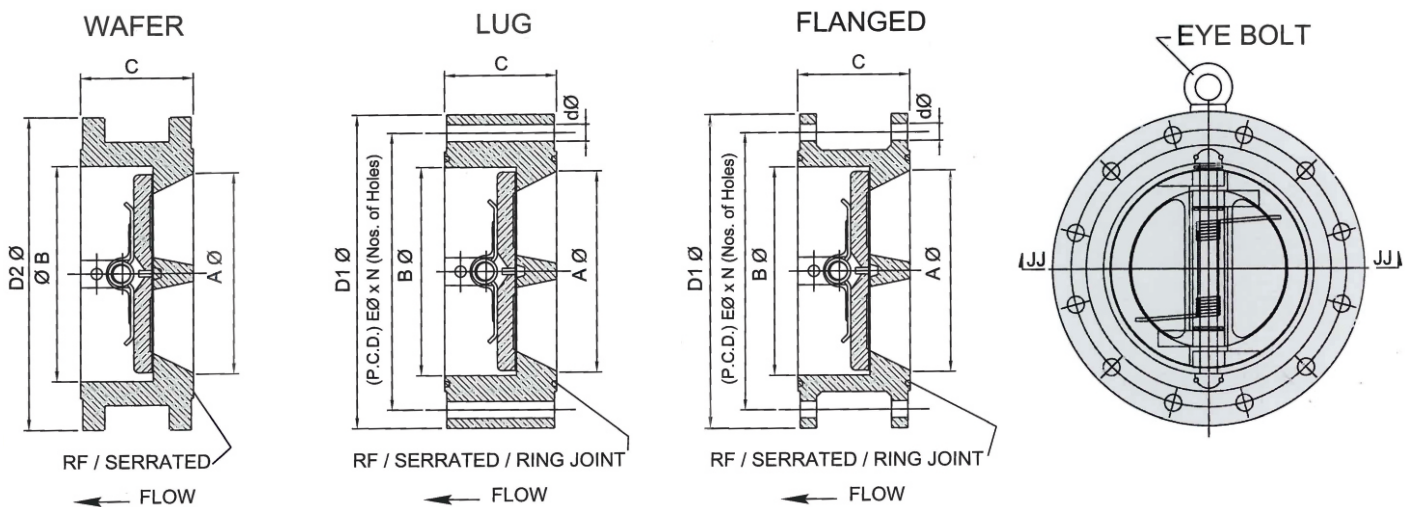

### SECTION - JJ

#### Installation Dimensions

Size : 2"~ 48"

Rating : ANSI # 150

Flange : ANSI B 16.5 / B 16.47

Size Inches (DN)	AØ mm	BØ mm	C mm	D1Ø Lug/Flg mm	D2Ø Wafer mm	EØ P.C.D. mm	N	dØ mm	End Facing	Approx Weight In kg.		
										Wafer	Lug	Flanged
2" (50)	50	60	60	152.4	105	120.6	4	19	RF/Serrated	3	7	-
2.5" (65)	65	75	67	177.8	124	139.7	4	19	RF/Serrated	5	12	-
3" (80)	76	90	73	190.5	134	152.4	4	19	RF/Serrated	7	12	-
4" (100)	100	114	73	228.6	172	190.5	8	19	RF/Serrated	9	19	-
5" (125)	125	135	83	254.0	196	215.9	8	22	RF/Serrated	14	25	-
6" (150)	150	168	98	279.4	222	241.3	8	22	RF/Serrated	16	32	-
8" (200)	200	225	127	342.9	279	298.4	8	22	RF/Serrated	26	63	-
10" (250)	250	274	146	406.4	340	362.0	12	25	RF/Serrated	48	93	-
12" (300)	300	325	181	482.6	409	431.8	12	25	RF/Serrated	78	-	125
14" (350)	337	365	184	533.4	450	476.2	12	29	RF/Serrated	90	-	144
16" (400)	387	418	191	596.9	514	539.7	16	29	RF/Serrated	100	-	176
18" (450)	432	432	203	635.0	549	577.8	16	32	RF/Serrated	140	-	210
20" (500)	489	489	219	698.5	603	635.0	20	32	RF/Serrated	180	-	270
24" (600)	591	620	222	812.8	718	749.3	20	35	RF/Serrated	274	-	380
30" (750)	642	695	305	984.3	882	914.4	28	35	RF/Serrated	625	-	790
36" (900)	900	936	368	1168.4	1048	1085.9	32	41	RF/Serrated	980	-	1140
42" (1050)	1050	1070	432	1346.2	1219	1257.3	36	41	RF/Serrated	1250	-	1900
48" (1200)	1200	1200	524	1511.3	1384	1422.4	44	41	RF/Serrated	2150	-	3350



# DUAL PLATE CHECK VALVE

## ANSI # 300

**Features** : Retainer Type / Retainer Less  
**Size** : 2" ~ 24"  
**Rating** : ANSI # 300

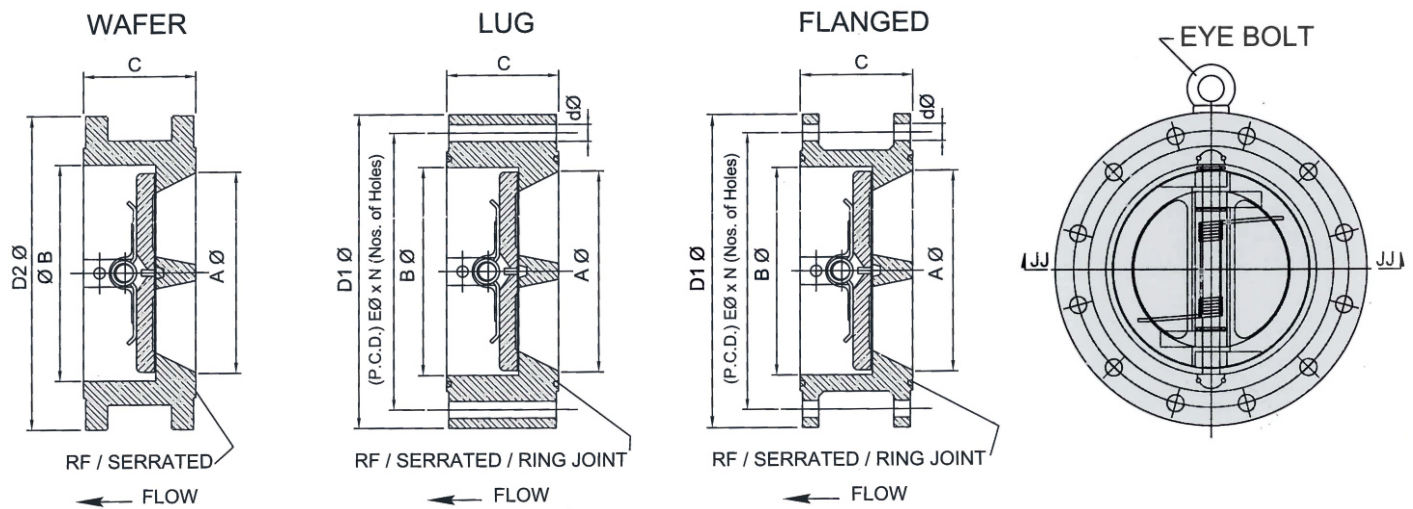

### SECTION - JJ

#### Installation Dimensions

Size : 2"~ 24"

Rating : ANSI # 300

Flange : ANSI B 16.5

Size Inches (DN)	A $\varnothing$ mm	B $\varnothing$ mm	C mm	D1 $\varnothing$ Lug/Flg mm	D2 $\varnothing$ Wafer mm	E $\varnothing$ P.C.D. mm	N	d $\varnothing$ mm	End Facing	Approx Weight In kg.		
										Wafer	Lug	Flanged
2" (50)	50	60	60	152.4	105	120.6	4	19	RF/Serrated	3	7	-
2.5" (65)	65	75	67	177.8	124	139.7	4	19	RF/Serrated	5	12	-
3" (80)	76	90	73	190.5	134	152.4	4	19	RF/Serrated	7	12	-
4" (100)	100	114	73	228.6	172	190.5	8	19	RF/Serrated	9	19	-
5" (125)	125	135	83	254.0	196	215.9	8	22	RF/Serrated	14	25	-
6" (150)	150	168	98	279.4	222	241.3	8	22	RF/Serrated	16	32	-
8" (200)	200	225	127	342.9	279	298.4	8	22	RF/Serrated	26	63	-
10" (250)	250	274	146	406.4	340	362.0	12	25	RF/Serrated	48	93	-
12" (300)	300	325	181	482.6	409	431.8	12	25	RF/Serrated	78	-	125
14" (350)	337	365	184	533.4	450	476.2	12	29	RF/Serrated	90	-	144
16" (400)	387	418	191	596.9	514	539.7	16	29	RF/Serrated	100	-	176
18" (450)	432	432	203	635.0	549	577.8	16	32	RF/Serrated	140	-	210
20" (500)	489	489	219	698.5	603	635.0	20	32	RF/Serrated	180	-	270
24" (600)	591	620	222	812.8	718	749.3	20	35	RF/Serrated	274	-	380

# DUAL PLATE CHECK VALVE

## ANSI # 600

**Features** : Retainer Type / Retainer Less  
**Size** : 2" ~ 24"  
**Rating** : ANSI # 600

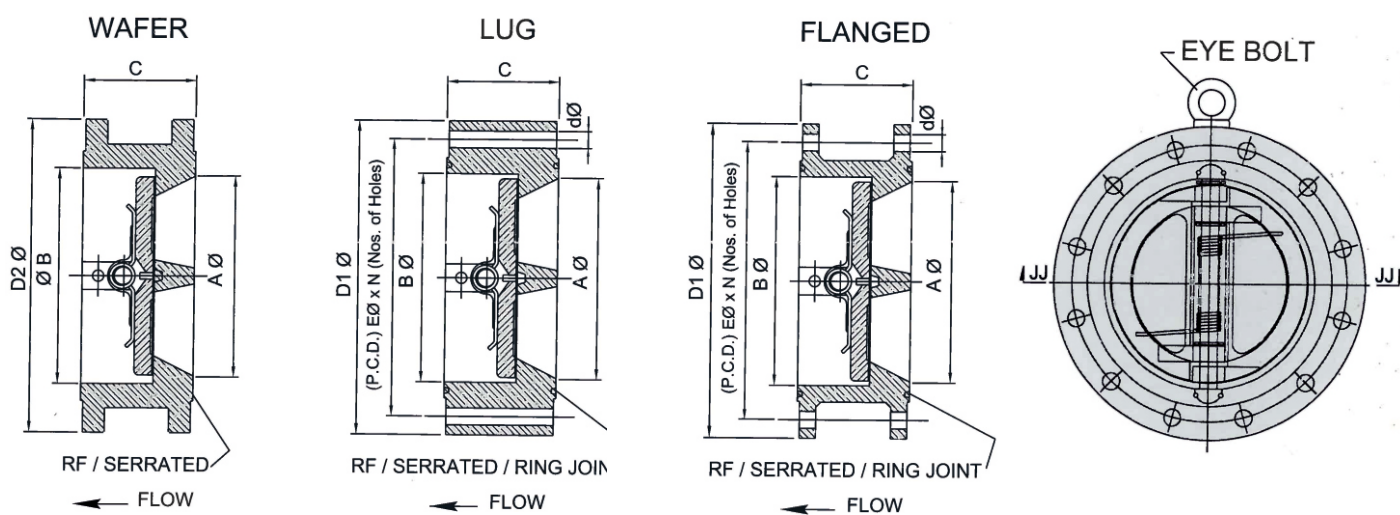

SECTION - JJ

### Installation Dimensions

Size : 2"~ 24"

Rating : ANSI # 600

Flange : ANSI B 16.5

Size Inches (DN)	AØ mm	BØ mm	C mm	D1Ø Lug/Flg mm	D2Ø Wafer mm	EØ P.C.D. mm	N	dØ mm	End Facing	Approx Weight In kg.		
										Wafer	Lug	Flanged
2" (50)	50	60	60	165.0	111	127.0	8	19	RF / R23	3.5	8	-
3" (80)	76	90	73	209.5	148	168.3	8	22	RF / R31	8	14	-
4" (100)	100	114	79	273.0	193	215.9	8	25	RF / R37	12	30	-
6" (150)	150	168	136	355.6	266	292.1	12	29	RF / R45	32	80	-
8" (200)	200	215	165	419.1	320	349.2	12	32	RF / R49	70	132	-
10" (250)	250	265	213	508.0	400	431.8	16	35	RF / R53	112	234	-
12" (300)	300	325	229	558.8	457	488.9	20	35	RF / R57	160	-	238
14" (350)	327	327	273	603.25	492	527.0	20	38	RF / R61	184	-	378
16" (400)	375	418	305	685.8	565	603.2	20	41	RF / R65	332	-	451
18" (450)	419	419	362	742.9	612	654.0	20	44	RF / R69	390	-	598
20" (500)	464	464	368	812.8	682	723.9	24	44	RF / R73	540	-	762
24" (600)	559	559	438	939.8	790	838.2	24	51	RF / R77	816	-	1142

# DUAL PLATE CHECK VALVE

## ANSI # 900

**Features** : Retainer Type / Retainer Less  
**Size** : 2" ~ 24"  
**Rating** : ANSI # 900

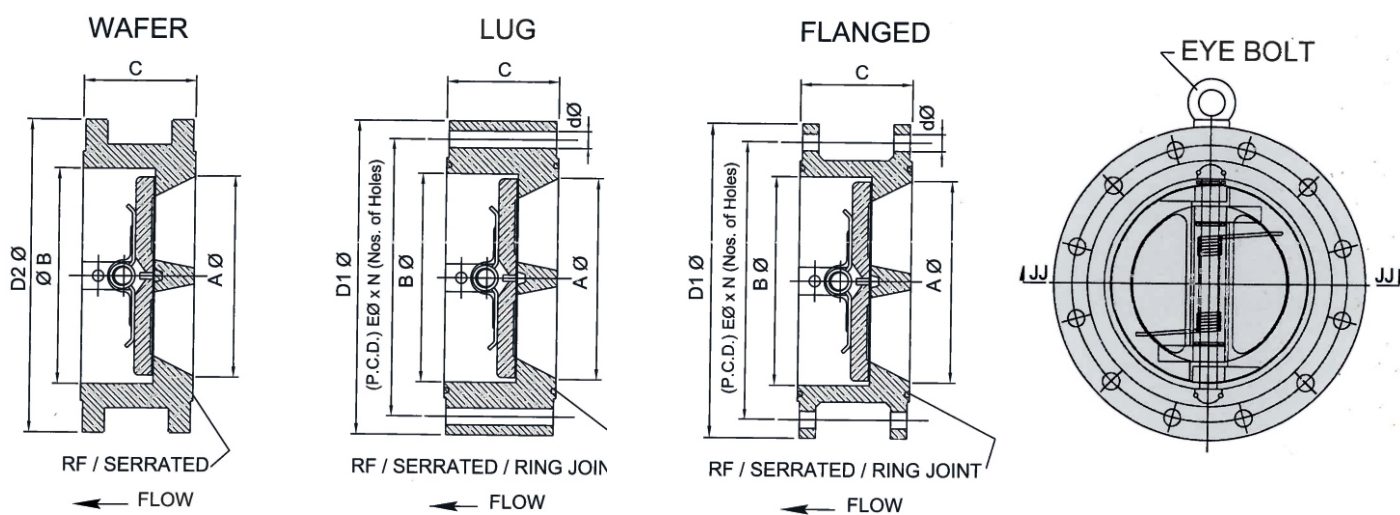

### SECTION - JJ

#### Installation Dimensions

Size : 2"~ 24"

Rating : ANSI # 900

Flange : ANSI B 16.5

Size Inches (DN)	AØ mm	BØ mm	C mm	D1Ø Lug/Flg mm	D2Ø Wafer mm	EØ P.C.D. mm	N	dØ mm	End Facing	Approx Weight In kg.		
										Wafer	Lug	Flanged
2" (50)	50	60	70	216.0	142	165.1	8	25	RF / R24	8.5	16	-
3" (80)	76	90	83	241.3	168	190.5	8	25	RF / R31	12	25	-
4" (100)	100	114	102	292.1	206	235.0	8	32	RF / R37	19	45	-
6" (150)	150	168	159	381.0	288	317.5	12	32	RF / R45	54	115	-
8" (200)	200	215	206	469.9	358	393.7	12	38	RF / R49	122	217	-
10" (250)	250	265	241	546.1	434	469.9	16	38	RF / R53	196	330	-
12" (300)	300	315	292	609.6	498	533.4	20	38	RF / R57	292	-	347
14" (350)	350	365	356	641.3	520	558.8	20	41	RF / R62	396	-	560
16" (400)	400	418	384	704.8	574	616.0	20	44	RF / R66	532	-	647
18" (450)	450	470	451	787.4	638	685.8	20	51	RF / R70	611	-	835
20" (500)	500	520	451	857.2	698	749.3	20	54	RF / R74	638	-	1783
24" (600)	559	620	495	1041.4	838	901.7	20	67	RF / R78	1230	-	1888

# DUAL PLATE CHECK VALVE

## ANSI # 900

**Features** : Retainer Type / Retainer Less  
**Size** : 2" ~ 24"  
**Rating** : ANSI # 1500

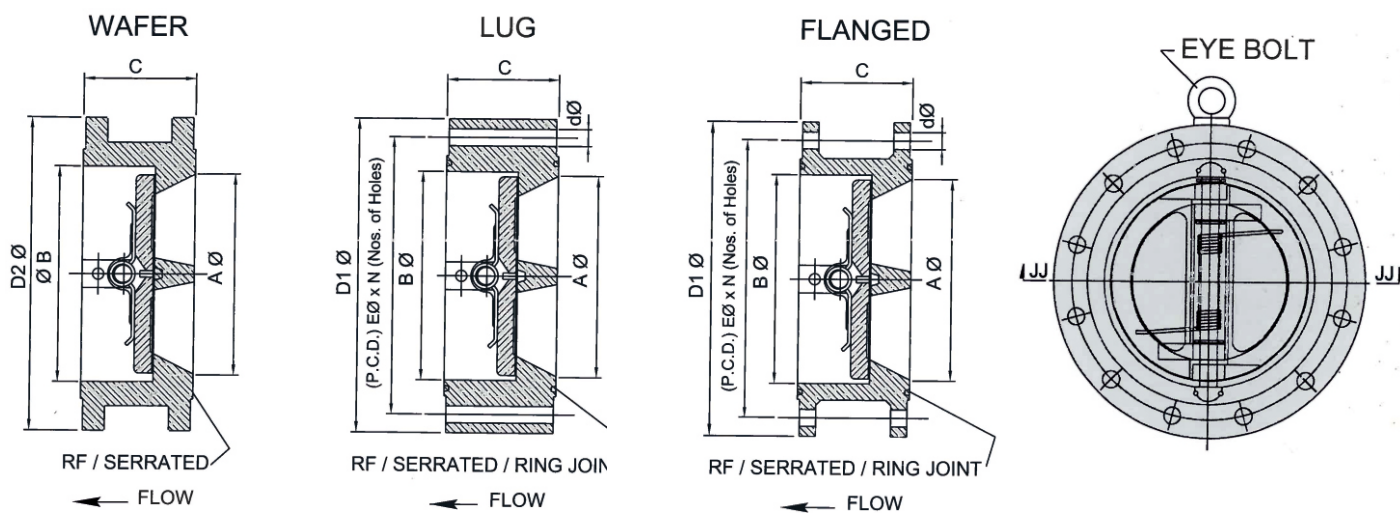

SECTION - JJ

### Installation Dimensions

Size : 2"~ 24"

Rating : ANSI # 900

Flange : ANSI B 16.5

Size Inches (DN)	AØ mm	BØ mm	C mm	D1Ø Lug/Flg mm	D2Ø Wafer mm	EØ P.C.D. mm	N	dØ mm	End Facing	Approx Weight In kg.		
										Wafer	Lug	Flanged
2" (50)	50	60	70	216.0	142	165.1	8	25.0	RF / R24	8.5	16	-
3" (80)	76	90	83	266.7	174	203.2	8	31.75	RF / R35	11	29	-
4" (100)	100	114	102	311.1	209	241.3	8	34.9	RF / R39	21	51	-
6" (150)	150	168	159	393.7	282	317.5	12	38.0	RF / R46	52	119	-
8" (200)	200	215	206	482.6	352	393.7	12	44.45	RF / R50	116	283	-
10" (250)	250	265	248	584.2	435	482.6	12	50.8	RF / R54	203	361	-
12" (300)	300	315	305	673.1	520	571.5	16	54.0	RF / R58	373	-	485
14" (350)	350	365	356	749.3	577	635.0	16	60.3	RF / R63	484	-	784
16" (400)	400	418	384	825.5	641	704.8	16	66.6	RF / R67	587	-	906
18" (450)	450	470	468	914.4	704	774.7	16	73.0	RF / R71	790	-	1170
20" (500)	500	520	533	984.2	755	831.8	16	79.3	RF / R75	1275	-	2498
24" (600)	600	620	559	1168.4	901	990.6	16	92.0	RF / R79	2713	-	2643

# DUAL PLATE CHECK VALVE

## ANSI # 2500

**Features** : Retainer Type / Retainer Less  
**Size** : 2" ~ 12"  
**Rating** : ANSI # 2500

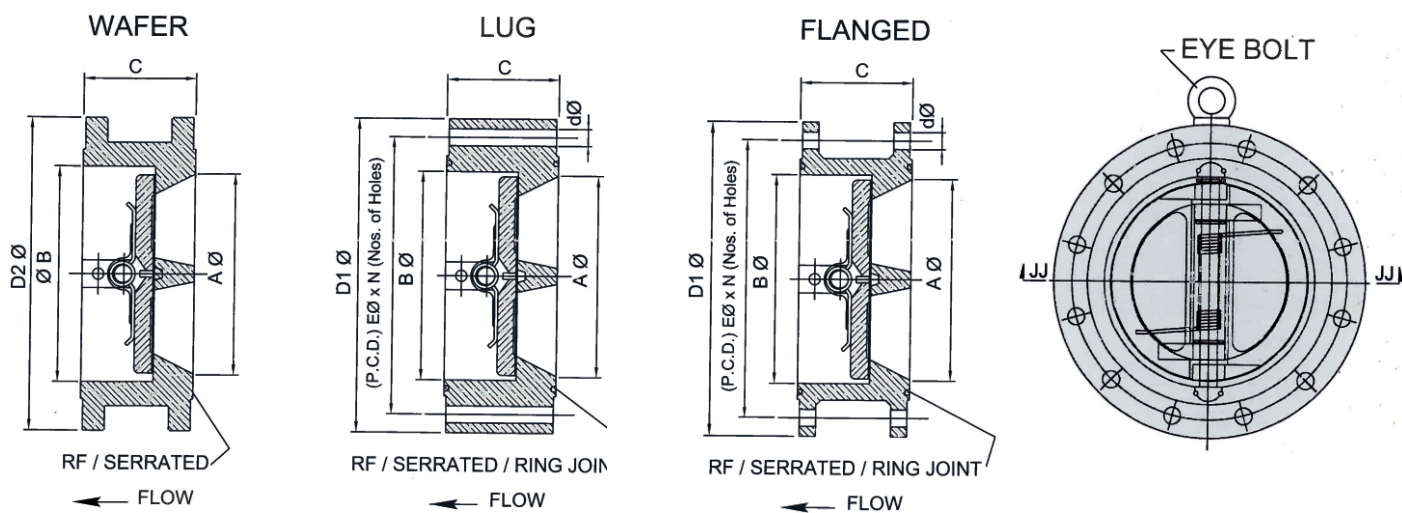

SECTION - JJ

### Installation Dimensions

Size : 2" ~ 12"

Rating : ANSI #2500

Flange : ANSI B 16.5

Size Inches (DN)	A $\varnothing$ mm	B $\varnothing$ mm	C mm	D1 $\varnothing$ Lug/Flg mm	D2 $\varnothing$ Wafer mm	E $\varnothing$ P.C.D. mm	N	d $\varnothing$ mm	End Facing	Approx Weight In kg.		
										Wafer	Lug	Flanged
2" (50)	50	60	70	235	146	171.4	8	29	RF / R26	13	19	-
3" (80)	76	90	86	305	196	228.6	8	38	RF / R32	16	38	-
4" (100)	100	114	105	356	234	273.0	8	41	RF / R38	29	69	-
6" (150)	150	168	159	483	317	368.3	8	54	RF / R47	70	184	-
8" (200)	200	215	206	553	387	438.1	12	54	RF / R51	132	396	-
10" (250)	250	265	254	673	476	539.7	12	67	RF / R55	216	489	-
12" (300)	300	315	305	762	548	619.1	12	73	RF / R60	394	-	596

# Material Selection Guide

Chemical Agents	Metals					Elastomers					Chemical Agents	Metals					Elastomers						
	Ductile Iron	410 ss	316 ss	Al. Bronze	Hastelloy C	Monel	EPDM	Buna N	Neoprene	Hypalon		Viton	Ductile Iron	410 ss	316 ss	Al. Bronze	Hastelloy C	Monel	EPDM	Buna N	Neoprene	Hypalon	Viton
Acetaldehyde Acetic Acid 50% 50 C Acetic Acid - Anhydride Acetone Acetylene	U U G G	U U G E	E E E E	U U E E	E E E -	F F E -	G G U U	U U U F	U G U U	U G U U	- U U U	Butyric Acid 5% Calcium Carbonate 60 F Calcium Chlorate 20% Calcium Chloride Calcium Chloride Solution	U F - F	G - G G	E - G E	- - - F	E E E E	- E E E	U E - E	U E E E	U E E E	F E E E	U E E E
Acrylonitrile Air (Dry) Alcohol - Amyl Alcohol - Butyl Alcohol - Ethyl	G E F F U	G E E G -	E E E E E	E E E E E	- - - - E	E E E E E	U E - - E	U U F G G	U E F G G	U E G U G	U G E U G	Calcium Hydroxide 50% 175 F Calcium hypochlorite Calcium Sulphate Carbon Dioxide Carbon Tetrachloride	E - F F U	E G E E G	E G E E F	U - - - -	U E - - G	E - - - U	E F G G U	E E G G U	E E E E E	E E E E E	
Alcohol - Methyl Alum - Ammonium Alum - Chrome Alum - Potassium Alumina	U U U G	- - - G	E G G G	E - - G	E - - -	E - - E	G G G -	G G F -	G F G G	U G G G	U G G G	Carbonic Acid Chlorine Gas - dry 70 F Chlorobenzene 90% Chromic Acid 5% 70 F Citric Acid 5% 150 F	U U U U	G F E E	G G E E	- F E F	E E E E	- U U U	- U U U	- U U U	- U U U	- G E E	- E E E
A1. Chloride A1. Fluoride A1. Hydroxide A1. Hydroxide Amines	U U U U	U - G G	U - - U	U - - E	- - - -	E - G -	E - G -	E G G -	E - G -	E E G -	E E G -	Coffee (food) Cooper Sulphate Cyclohexane Dextrose (food) Diacetone	U F F U U	G E E U -	E E E - E	U - U -	- - - -	E E E E	U E E E	E E E E	E E E E	E E E E	
Ammonia, Anhydrous Ammonia Gas 150 F Ammonia Solutions Ammonium Chloride 50% 180 F Ammonium Hydroxide	F U F U	G U G E	E E U U	U U E U	- - E E	- G G F	E G G -	- - G -	U U U G	U U U G	U U U G	Dichloroethene Diesel Fuels Diethyl Amine Dowtherms Drilline Mud	U F F G G	- E E E -	F E E E	- G E -	- E E E	U U U U	U U U U	U U U U	U U U U	G E E E	
Ammonium Nitrate 5% 60 F Ammonium Phosphate Ammonium Sulphate Amyl Acetate Amyl Chloride	F U U F	G F G E	E G E E	U U G E	E G G -	G E G -	- E E -	E E E -	F E E U	- E E U	- E E U	Ethers Ethyl Acetate Ethyl Chloride 5% Ethyl Glycol Ethylene Oxide	U F F G G	- G E E E	E E E E	E E E -	G E G E	U G E U	U E E E	U E E E	U U U U	- U E E	
Aniline 90% 70 F Asphalt Barium Carbonate 60 F Barium Chloride Barium Hydroxide	F U U F	G E - E	E E - E	E E G G	- E G -	G E E -	U E E E	U U E E	U U E E	U U E E	G E E -	Fats Ferric Chloride Ferric Nitrate Ferric Sulphate 5% Ferrous Sulphate	E U U U	E - E G	E E - E	- U U -	E E E E	U - G E	E F E E	G F E E	G F E E	- F F E	- - E G
Barium Sulphate Barium Sulphate Beer (Beverage) Beer Sugar Solution Benzaldehyde	U F U F	- E E E	E E U E	G U E E	- - - -	G E E G	E - E -	E - - G	E E G U	E E U U	E E U U	Fluorine Fluosilicic Acid Formaldehyde 70 F Fromic Acid 5% 150 F Freon	U U U U F	U F G E E	U E E E E	U E E E E	- - G E	- E E E	G G E U	F E E E	G E E E	G E E E	- E E E
Benzene (benzol) 70 F Benzoic Acid 5% Borax Boric Acid 5% 200 F Brine	F U U U U	E G F E -	E - E E E	E E E G	G G G G	- - - G	U - E E	U F E E	U F E E	U F E E	U F E E	Fruit Juices (food) Fuel Oil Gallie Acid 5% 200 F Gasoline Glucose	U F U F U	U E - E F	E E E G E	U E E - G	- G - G -	G U - U -	G F E E	G F E E	- U E E	- F E E	- E E E
Bromine - Gas Bromine - Water Butadiene Butane - Buthylene Buthyl Acctate	U U F G G	U U G E E	U - E E E	- E E E	E F - -	F F - -	U U - G U	U U - G U	U U - G U	U U - G U	G G G G U	Glycerine / Glycerol Heptane Hexane Hydrobromic Acid 200 F Hydrochloric Acid 15% 60 F	F F U U	E G E U U	E E E U E	G E E E E	- U U U U	E E E E	E G G U	E G G U	E G G U	E G G U	

**Code:**

**E:** Excellent - The fluid has from a null to minimum effect  
**F:** Fair - The fluid has from moderate to severe effect

**G:** Good - The fluid has from minimum to moderate effect  
**U:** Unsuitable

Chemical Agents	Metals					Elastomers					Chemical Agents	Metals					Elastomers												
	Ductile Iron	410 ss	316 ss	Al. Bronze	Hastelloy C	Monel	EPDM	Buna N	Neoprene	Hypalon		Viton	Ductile Iron	410 ss	316 ss	Al. Bronze	Hastelloy C	Monel	EPDM	Buna N	Neoprene	Hypalon	Viton						
Hydrochloric Acid 37% 60 Hydrofluoric Acid 20% Hydrofluoric Acid 20 - 60% Hydrogen Hydrogen Peroxide 90%	U	U	U	U	E	U	U	U	E	E	Propane Resins Sea Water 70 F Soap Solution (strearate) Sodium Acetate 5%	E	E	E	E	-	-	U	E	E	E	E							
Hydrogen Sulfide Iodine Solution Iso-octane Isopropyl Alcohol Isopropyl Ether	F	F	G	F	-	-	E	U	G	F	U	Sodium Bisulfate Sodium Carbonate Sodium Chloride 30% 180 F Sodium Cyanide Sodium Fluoride 5% 60 F	U	F	E	-	-	-	-	E	E	-	-	E					
Kerosene Lactic Acid 5% Lubricating Oil Magnesium Chloride 4% Magnesium Hydroxide	E	E	E	E	E	E	U	E	F	F	E	Sodium Hydroxide 50% 122 F Sodium Hydroxide 50% 176 F Sodium Hypochlorite 5% 60 F Sodium Nitrate Sodium Perborate	U	F	G	U	E	G	E	U	G	E	U	G	E	U			
Magnesium Sulphate Mercuric Chloride 3% Mercury Methane Methyl Acetate	F	G	E	E	E	E	E	E	E	E	E	Sodium Peroxide Sodium Phosphate 5% Sodium Silicate Sodium Sulfide 70% Sodium Sulfite	U	G	E	U	-	-	E	G	G	G	E	E	G	G	E		
Methyl Acetone Methyl Chloride Methyl Ethyl Ketone Milk (Food)	F	E	E	E	-	-	G	U	U	U	U	Sodium Sulphate 80% 60 F Steam 300 F Stearic Acid 90% 200 F Sulphur (Molten)	U	G	E	G	E	G	E	E	E	E	E	E	E	E	E		
Mineral Oil Molasses (Food) Naphthalene Natural Gas Nickle Chloride	F	-	F	-	E	-	U	E	G	G	E	Sulphur Dioxide Sulphur Trioxide Sulphuric Acid 10% Sulphuric Acid 50% Sulphuric Acid 93% 70 F	U	G	E	F	E	E	G	U	U	F	U	F	U	G	E	E	
Nitric Acid Less 40% 70 F Nitric Acid More 40% 70 F Nitrobenzene Oleum Olive Oil	U	-	-	U	G	U	U	U	U	E	E	Sulphurous Acid 80% 100 F Tannic Acid 10% 150 F Tar Tartaric Acid 150 F Thinner	U	U	U	U	E	U	U	U	-	F	F	E	E	E	E	E	
Oxygen 200 F Oxygen 300 F Palmitic Acid Perchloroethylene Petroleum	E	E	E	E	E	E	E	G	G	G	E	Tributyl Phosphate Trichloroethylene Tricresyl Phosphate Triethanolamine Turpentine	U	F	E	-	-	-	U	U	U	U	G	E	U	U	U	G	F
Phenol Phosphoric Acid 5% Phosphoric Acid 85% 70 F Picric Acid 80% Potassium Cyanide	U	-	E	-	E	E	U	U	U	U	E	Vinegar 70 F Water - Demineralized Water - Distilled Water - Fresh Water - Mineral	U	-	E	-	E	-	E	E	E	E	E	E	E	E	E	E	E
Potassium Hydroxide 5% Potassium Nitrate Potassium Phosphate Potassium Sulfide Potassium Sulfite	F	G	E	F	E	G	E	E	E	E	E	Water - Sewage Whiskey and Wines Xylene, Xylol Zinc Chloride 5% 160 F Zinc Sulphate 25% 180 F	U	G	E	E	E	E	E	E	E	E	E	E	E	E	E	E	E

# Ordering Instruction for Dual Plate Check Valve

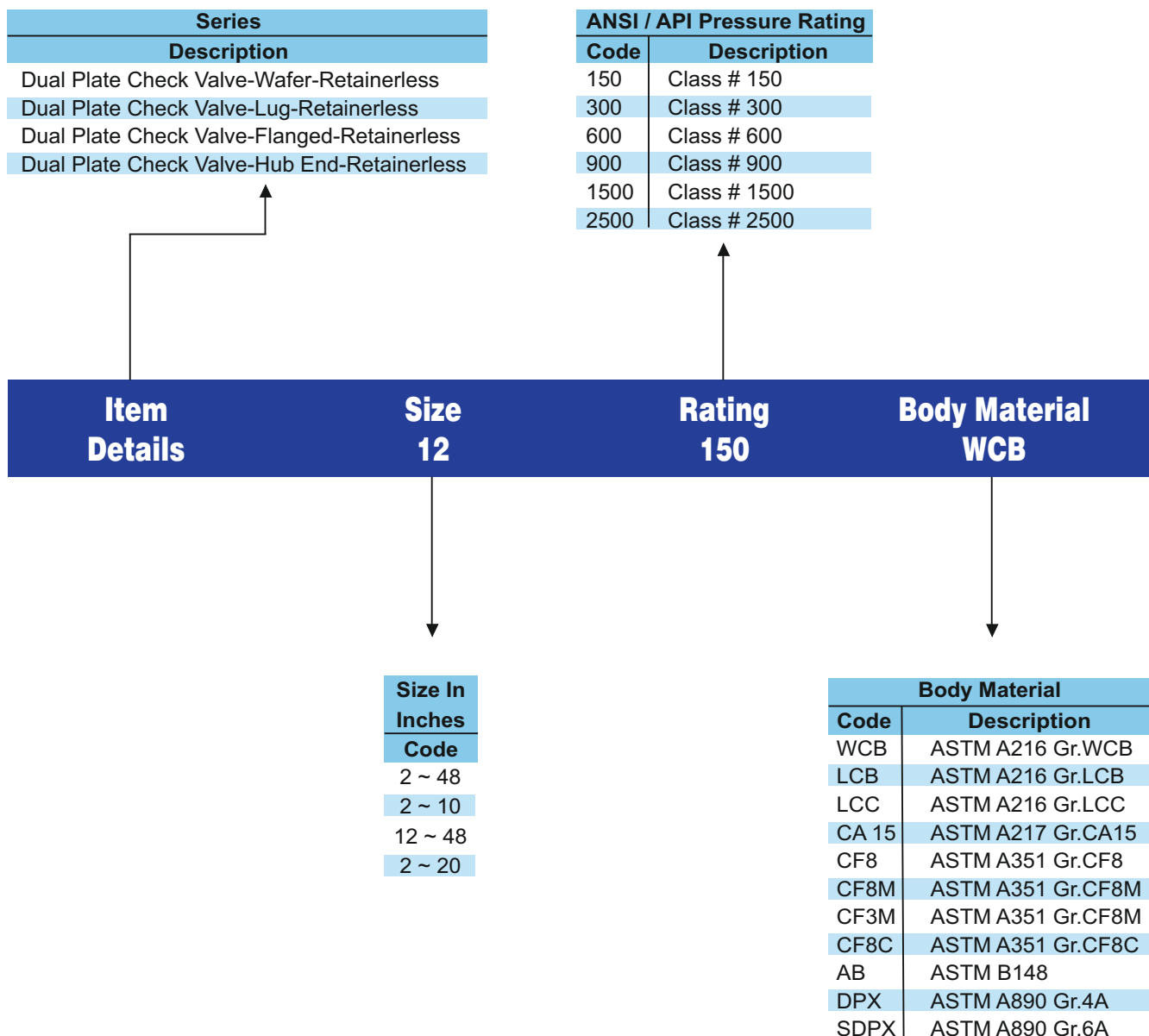

## Notes

**Example : 12-150-ECB/CF9M/MM/INCONEL/RF**

1. For dimensions refer to respective series
2. Please specify any other testing/ material certification required
3. Certification : As per EN-3.1 B

The Company reserves the right to change product design and specification without notice



Plate Material	
Code	Description
WCB	ASTM A216 Gr.WCB
CA 15	ASTM A217 Gr.CA15
CF8	ASTM A351 Gr.CF8
CF8M	ASTM A351 Gr.CF8M
CF3M	ASTM A351 Gr.CF8M
CF8C	ASTM A351 Gr.CF8C
AB	ASTM B148
DPX	ASTM A890 Gr.4A
SDPX	ASTM A890 Gr.6A

Spring	
Code	Description
SS 316	AISI 316
Inconel	Inconel X750

**Plate Material**  
CF8M

**Body Seat**  
Metal to Metal

**Spring**  
Inconel

**End Facing**  
RF

Body Seat	
Code	Description
MM	WCB, As Body Material
MM	CF8M, As Body Material
MM	13% Cr. Overlay
MM	SS 316 Overlay
MM	Stellite - 6
Viton	Viton
Buna-N	Buna-6
Neo	Neoprene
EPDM	EPDM

End Spring	
Code	Description
SF	Smooth Face 125-250 AARH
RF	Raised Face 250-500 AARH
RTJ	Ring Type Joint

# HUB END CHECK VALVE

**ANSI # 600, # 900, # 1500, # 2500**



## Applications

- Onshore, Offshore & subsea pipeline application
- Oil and Gas Production
- Petrochemical
- Industrial Piping
- Power Generation

**Size Range:** 2" ~ 20"

**Rating:** ANSI #600, #900, #1500, #2500

**Seat:** Metal to Metal

## Features

- Up to 75% lighter and significantly smaller than a comparable ANSI or API flanges
- Close piping and hook-up arrangements with typically 25% smaller clamp diameter
- Typically 40% shorter connection lengths
- Easier fabrication and installation with no bolt holes to align
- Only 4 bolts to tighten rather than up to 24 on a conventional flange
- The clamp can be rotated completely round the hub for easy bolt orientation and tightening
- Quicker and easier assembly and disassembly minimizing maintenance downtime
- Dimension on request
- Users to specify make of clamp e.g. Graylok, Techlok, Clamplok
- All valves are rated in accordance with ANSI B16.34, API 594, API 598 Design
- DCHR valves have reduced bore internals, usually one size down

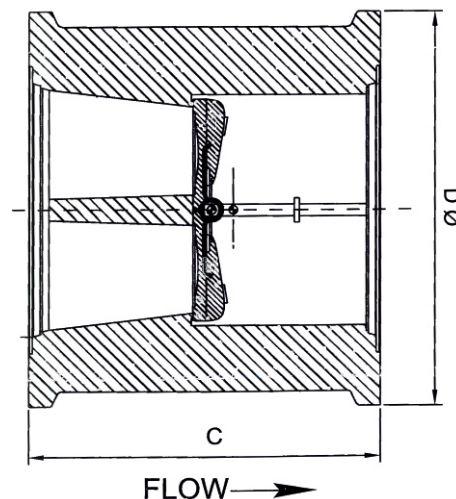
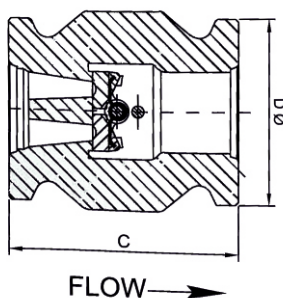

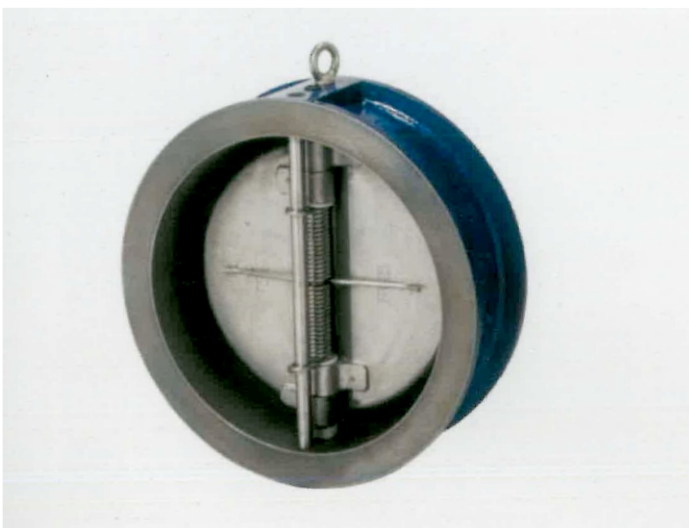
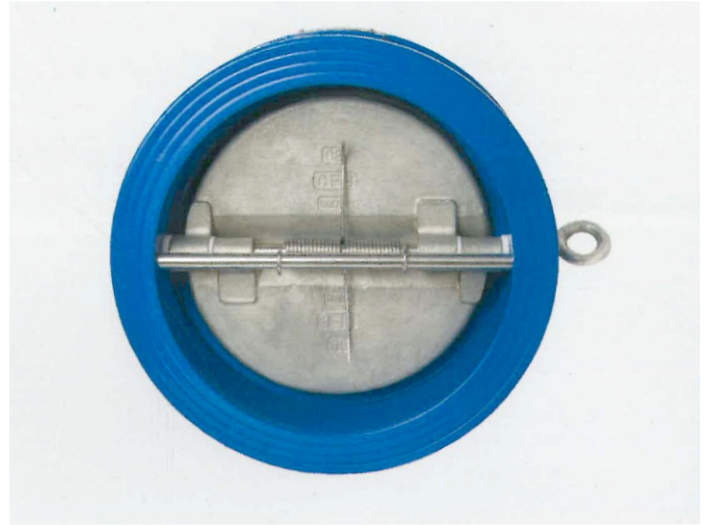
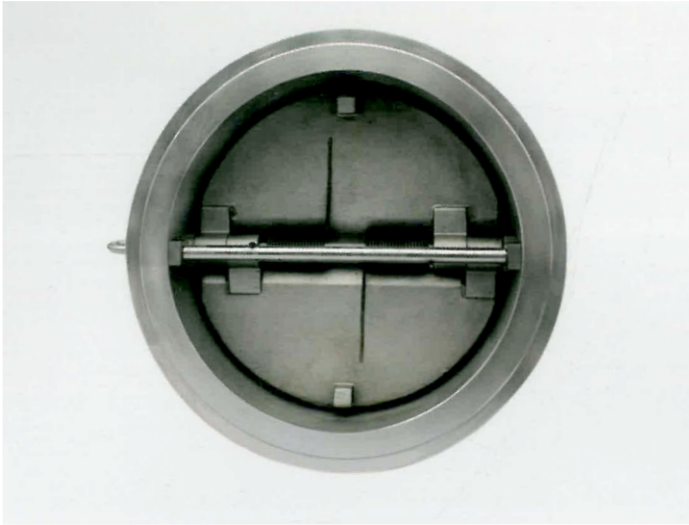

## IN HOUSE TESTING FACILITIES INCLUDE

FACTORY  
ACCEPTANCE  
TEST (FAT)

HYDROSTATIC  
SHELL & SEAT  
TESTING

LOW & HIGH  
PRESSURE GAS  
TESTING

CRYOGENIC  
TESTING

LOW  
TEMPERATURE  
TESTING

HIGH  
TEMPERATURE  
TESTING

FUGITIVE  
EMISSION  
TESTING (FET)

ENDURANCE  
CYCLIC TESTING

FIRE SAFE  
TESTING

*Alka Tech Industrial Valve & Fittings Co. has an advanced manufacturing setup with automated valve test equipment. In-House Research and Development has an advanced setup for new design validation tests (DVT).*

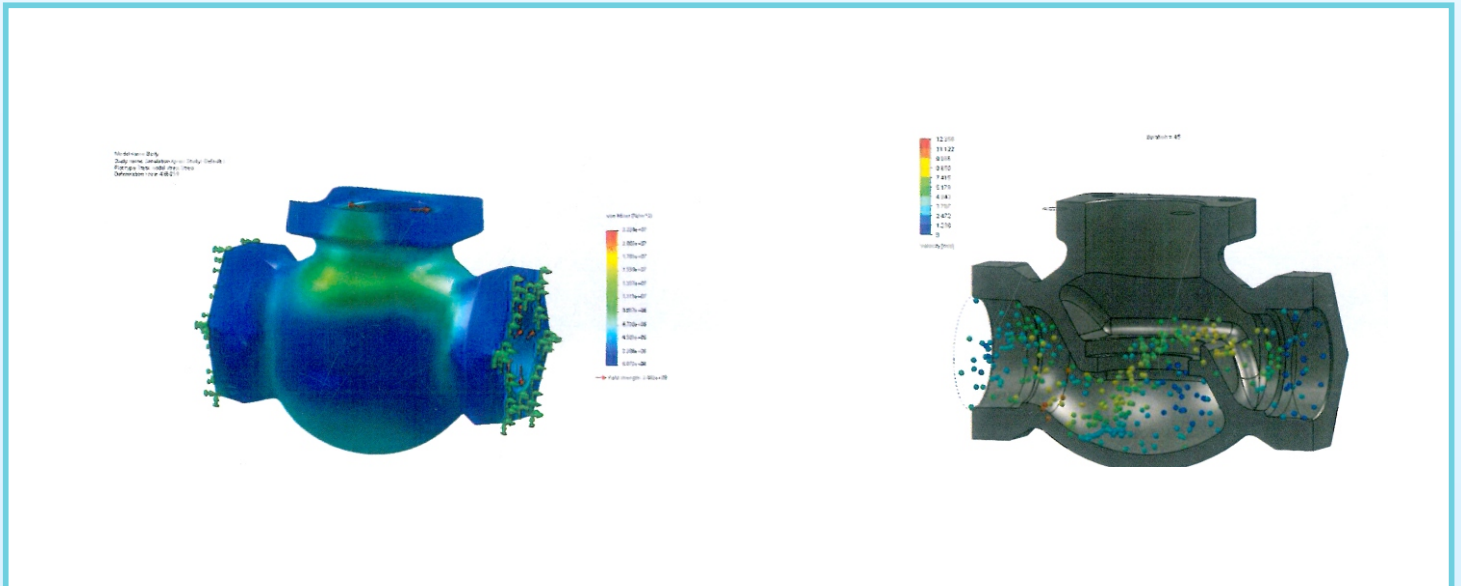

*Our research and development team continuously upgrade our valves to meet latest standards and customer requirements hence the data given here in is subject to change.*

+91 9833835078 / +91 9029969497

✉ john.alkatech@gmail.com

🌐 www.alkatechvalves.com

✉ john@alkatechvalves.com

**Office : Shop No.5, Victor Shelter Bldg, Mithagar Road, Dahisar West,  
Mumbai - 400068.**

**Works Unit 1 : V-48/V-49, Kanabargi Industrial Area, Auto Nagar, Balagavi,  
Karnataka - 590015.**

**Works Unit 2 : 103, POR Ramangamdi Ind. Estate, Vadodra - 391243.**